

***X-ray Double Crystal
Monochromators
for Advanced Photon Source,
Argonne National Laboratory
HLD and APM series***

Technical Specifications

July 1998

X-ray Double Crystal Monochromators for Advanced Photon Source, Argonne National Laboratory

Contents

I. General

- I.1. Introduction ······P1**
- I.2. Design Concept ······P2**
- I.3. Design Variations ······P2-3**

II. Mechanics

- II.1. Definitions ······P4**
- II.2. General Specifications ······P5**
- II.3. Main Rotation Axis ······P6**
- II.4. First Crystal Part ······P7**
- II.5. Second Crystal Part ······P8-10**
- II.6. Sagittal focusing ······P11**
- II.7. Supporting Table ······P12**
- III. Vacuum Chamber ······P13**
- IV. Electrical Connections ······P14**
- V. Cooling system ······P15**
- VI. General View Drawings ······P16-17**

I. General

1. Introduction

Multiple Bragg reflection from high quality Silicon, Germanium and Diamond single crystals is a standard method to obtain highly monochromatic X-rays. A double crystal monochromator with two parallel crystals produces a monochromatic exit beam running parallel to incident white X-ray beam. The energy of the exit beam depends on the angle of incidence, or Bragg angle θ . Commonly it is required that the beam offset, or distance between the optical axes of the incident beam and the exit beam, does not change during energy scan.

This requirement can be achieved by independent control type or by mechanically coupled monochromators. The first type has independent goniometers for each crystal. Rotations and translations of the crystals mounted on these goniometers are remotely controlled and synchronized by computer. The second type has a common rotating table, which holds both crystals and their adjustment mechanics. The motion of the crystals on horizontal and vertical translation stages is either guided by a cam or by independently controlled translation stages. Generally, the independent control type is more precise. On the other hand, it requires more space, which makes it difficult to provide a high vacuum environment. The mechanically coupled type is compact, however it is less precise.

Highly intense X-rays emitted from insertion devices of third generation high energy storage rings impose challenges on the design of monochromators. The heat load on the first crystal is estimated to be of the order of $100\text{W}/\text{mm}^2$ and more. The radiation level in the monochromator vessel, or vacuum chamber, is also extremely high. This requires a system that efficiently removes heat from the crystal while maintaining high vacuum in the chamber. All materials used inside the chamber have to be radiation proof.

The design principles of the HLD and APM series monochromators we offer here have been worked out for the Advanced Photon Source (APS) of Argonne National Laboratory, while KOHZU Seiki Co., Ltd. was in charge of design and construction of the monochromators. HLD and APM monochromators are double crystal mechanically coupled types with both crystals mounted on a common rotating table and moved independently by vertical and horizontal translation stages. Each monochromator is provided with effective crystal cooling system. The first monochromator of HLD series was delivered to APS in January 1994.

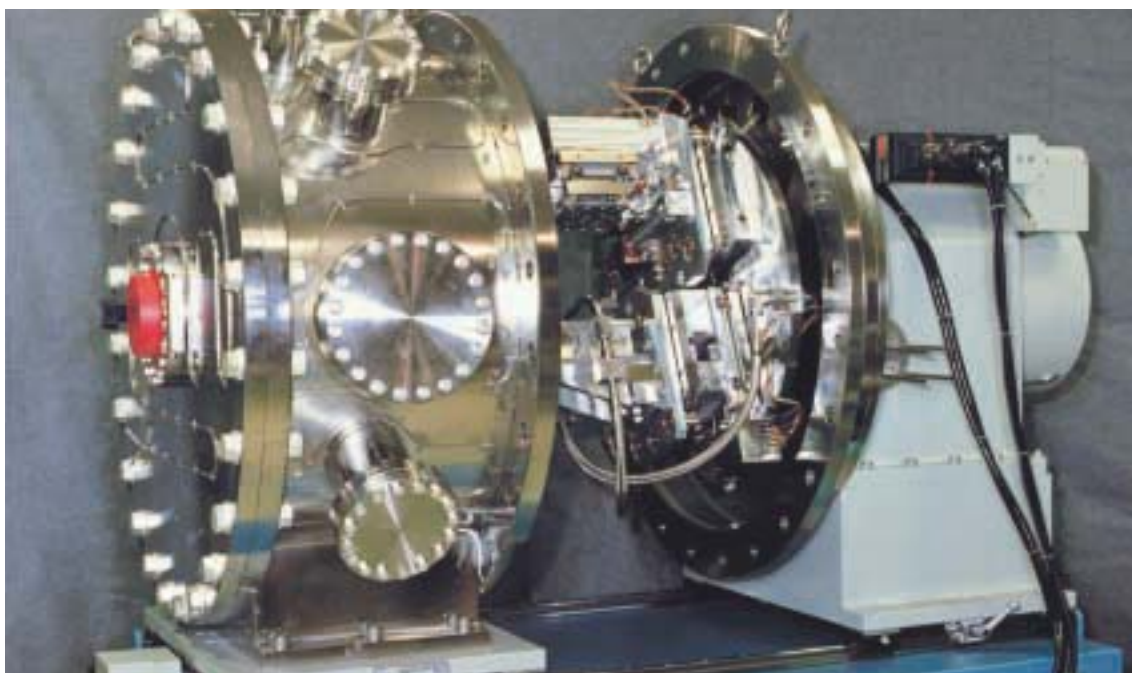

HLD-1 monochromator.

I. General

2. Design Concept

The heart of the monochromator is a precise main rotation axis mechanism held by a column placed on the top of the supporting table. On one side of the column there is a motor, high resolution rotary encoder and high precision gear system which actuates the main rotation axis shaft. A side flange of the cylindrical vacuum chamber of the monochromator is fixed to the other side of the column. The shaft is introduced to vacuum through a ferrofluid seal, which provides high vacuum tightness and smoothness of rotation. There is a common rotating table on the vacuum end of the shaft, which carries adjustment mechanics of both crystals. This mechanics includes translation stages which maintain the fixed beam offset, as well as precise adjustment of Bragg angle, translation, tilting and sagittal focusing according to specifications below. There are tubes provided for the cooling medium.

The bottom of the chamber body and the column are placed on the same rails perpendicular to the beam direction. The column can be moved freely, while the chamber body motion is actuated by a translation mechanism. Access to the mechanics inside vacuum chamber can be provided by pulling out the column with the main axis shaft, common rotation table and the vacuum chamber side flange, or by opening the other side flange.

Supporting table of the monochromator allows transverse horizontal (as described above) and vertical translation of the whole monochromator as specified below. Rough alignment in the beamline can be done by adjustment bolts on the bottom of the table.

3. Design Variations

There have been produced two nearly identical monochromators HLD-1 and HLD-2, and two mirror symmetric monochromators APM-2L and APM-2R. Two newest monochromators HLD-3 have been just delivered to APS (July, 1998). The data about deliveries are summarized in the table below:

Model	HLD-1	HLD-2	HLD-3	APM-2
Installed at	SRI-CAT, sector 1	SRI-CAT, sector 3	Mu-CAT sector 6 CHEM/MAT-CARS sector 15	SRI-CAT, sector 2
Scientist in charge	Dr.W-K. Lee	Dr.E.Alp	Dr.D.Robinson Dr.J.Viccan	Dr. B.Lai Dr.W-B.Yun
Number of monochromators delivered	1	1	2	2 (mirror symmetry)
Date of delivery	January 1994	April 1995	July 1998	June 1995

Both HLD and APM type monochromators of the same size are placed in similar vacuum chambers. The rotation table and the main axis rotation mechanism is also the same for all types. However, the mechanism which maintains the beam offset constant is different. There are also differences in the adjustment mechanisms of the crystals and the cooling system for each type of monochromator according to the specifications.

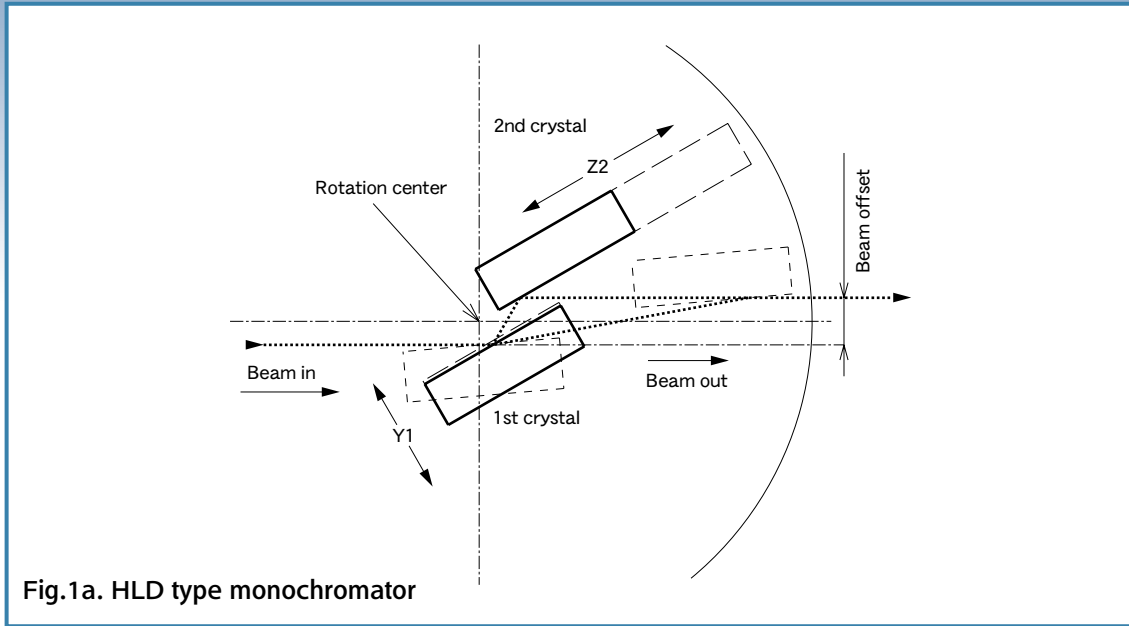

HLD type monochromators have the 1st crystal shifted downwards from the rotation center (about half of the offset value), while the surface of the 2nd crystals lies in the plane which crosses the rotation axis (fig.1a). In order to keep the offset constant there are vertical translation $Y1$ and horizontal translation $Z2$ (the directions correspond to $\theta = 0^\circ$ according to definitions given below) of the 1st and 2nd crystal respectively. Solid lines on fig.1a show the position of both crystals at $\theta = 30^\circ$, while short dashed lines show the positions at $\theta = 5^\circ$. The motion range of both crystals is shown by long dash lines (at $\theta = 30^\circ$). The beam footprint on the 2nd crystal moves with the change of Bragg angle θ .

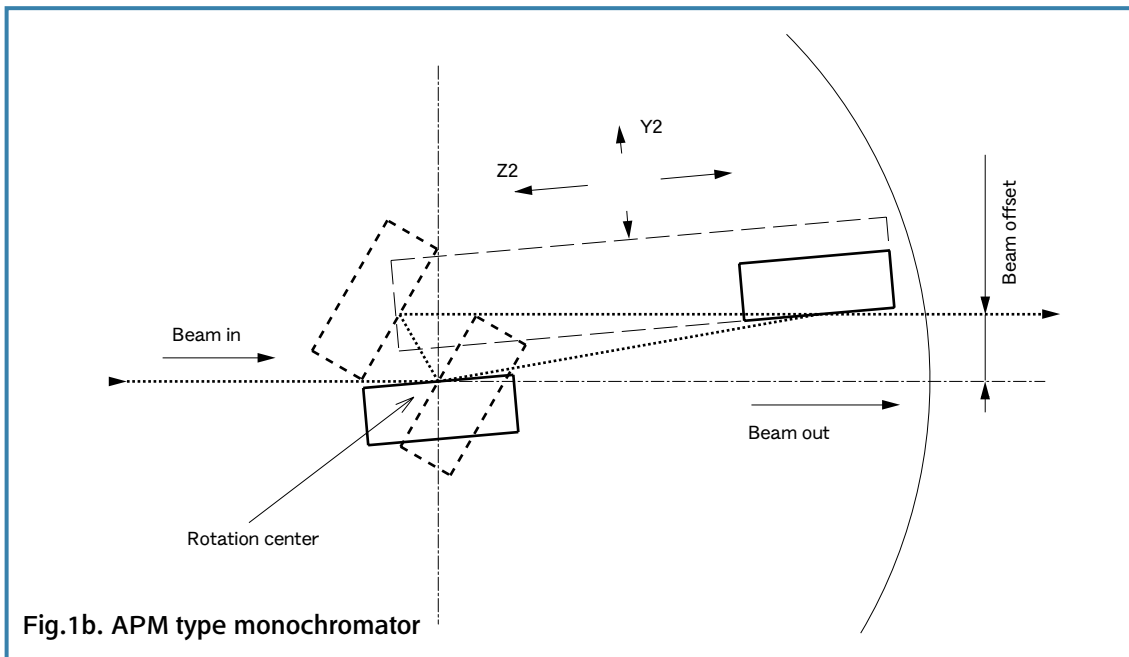

APM type has the 1st crystal in the rotation center, while the second crystal can move horizontally and vertically (translations $Z2$, $Y2$ respectively) as shown on fig.1b. Solid lines show the position of both crystals at $\theta = 5^\circ$ while short dashed lines show the position at $\theta = 60^\circ$. The motion range of the 2nd crystal (at $\theta = 5^\circ$) is shown by long dash lines. The beam footprint on the 2nd crystal moves as in the case of HLD monochromator.

II. Mechanics

1. Definitions

We use here following Cartesian coordinate system. The beam propagation direction coincides with the Z axis, Y axis shows vertical direction and X axis is perpendicular to both Z and Y. Pitch θ means rotation around X axis, yaw ϕ and roll χ are rotations around Y and Z axes respectively.

Theoretical resolution is the smallest amount of motion which is expected to be provoked by the actuator. Usually it corresponds to one step of stepping motor.

Resolution is the smallest amount of motion which can be executed by the mechanics with 10% accuracy.

Accuracy shows maximum difference between the amount of motion commanded to the actuator and really executed by the mechanics for any motion within the specified range. Absolute accuracy means accuracy within the whole range of motion.

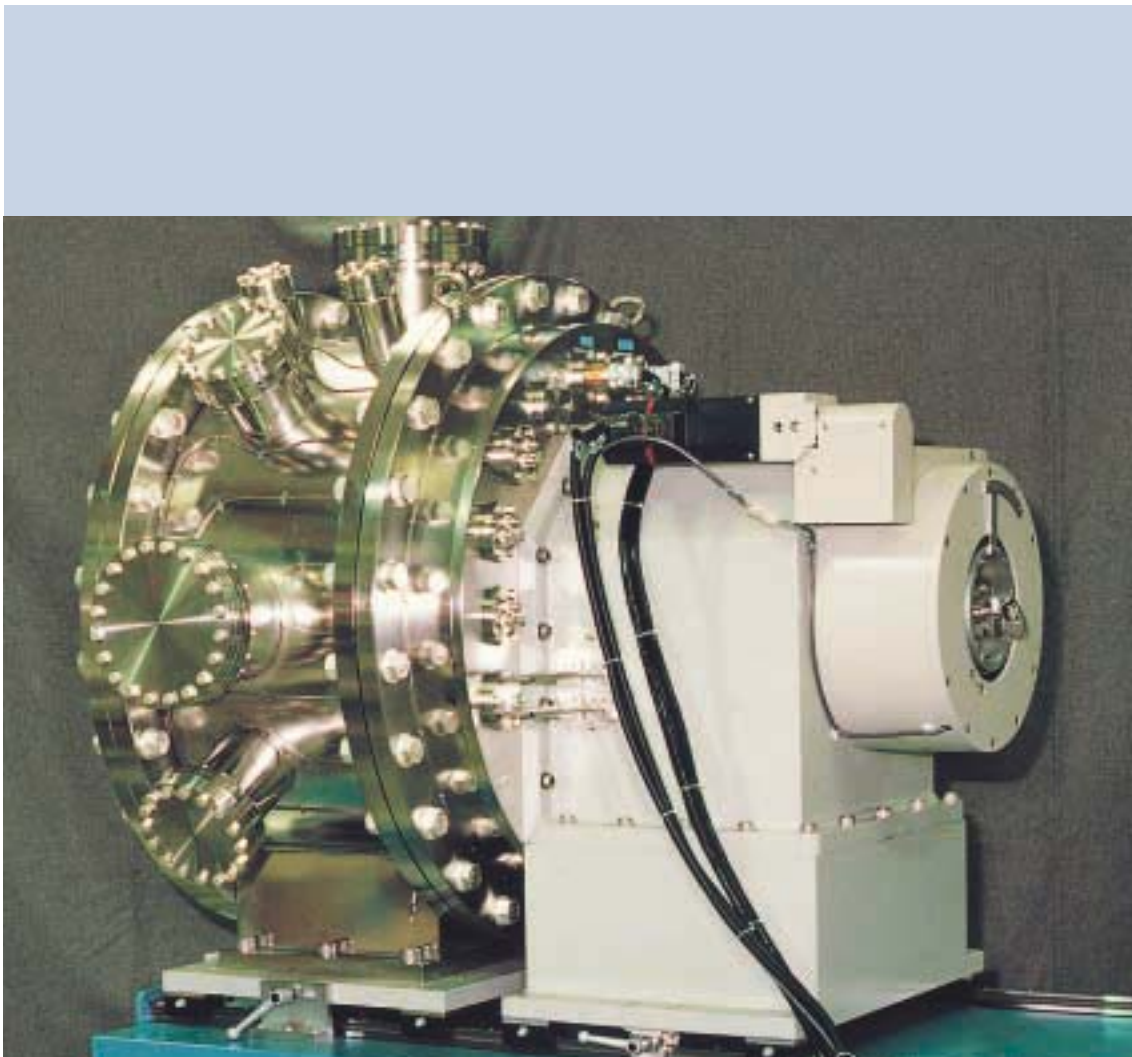

HLD-1 monochromator : the main axis supporting column.

2. General Specifications

Model	HLD-1	HLD-2	HLD-3	APM-2
Bragg angle θ (main axis)	5° - 30°	5° - 30°	5° - 40°	5° - 60°
Energy (Si111)	4.0 - 22.5 keV	4.0 - 22.5 keV	3.1 - 22.5 keV	2.3 - 22.5 keV
Incident beam height ¹⁾	1390mm	1390mm	1387.5mm	1400mm
Exit beam height ¹⁾	1425mm	1425mm	1412.5mm	1410 - 1435mm
Beam offset	35mm upwards	35mm upwards	25mm upwards	10 - 35mm upwards
Beam in - beam out flange distance	940mm (1250mm with beam monitor)	940mm (1250mm with beam monitor)	940mm (1250mm with beam monitor)	940mm (1250mm with beam monitor)
Supporting structure area	800×1300mm ²	800×1300mm ²	800×1300mm ²	800×1300mm ²
Weight	~2100kg	~2100kg	~2100kg	~2100kg
Ultimate pressure	3 · 10 ⁻⁷ mbar	3 · 10 ⁻⁷ mbar	3 · 10 ⁻⁷ mbar	3 · 10 ⁻⁷ mbar
Baking compatibility	150°C ³⁾	no	no	no
1st crystal adjustment mechanism sequence ⁴⁾ (all motorized)	Vertical Y ₁ Pitch θ_1	Vertical Y ₁ Pitch θ_1	Vertical Y ₁	no
2nd crystal adjustment mechanism sequence ⁴⁾ (all motorized)	Longitudinal Z ₂ Pitch θ_2 Transverse X ₂ Roll χ_2	Longitudinal Z ₂ Pitch θ_2 Transverse X ₂ Roll χ_2	Longitudinal Z ₂ Pitch θ_2 Transverse X ₂ Yaw χ_2	Longitudinal Z ₂ Vertical Y ₂ Pitch θ_2 Roll χ_2
2nd crystal bending mechanism (motorized)	no	no	provided	no
Supporting table adjustment mechanism sequence ⁵⁾ (except *-mark all motorized)	Vertical Y _T Transverse X _T	Vertical Y _T Transverse X _T	Vertical Y _T Transverse X _T	Vertical Y _T Transverse X _T *

1) For "0" setting of vertical translation stage of the supporting structure.

2) Measured at the exit flange position.

3) Temperature of the seal of the main axis shaft should not exceed 80°C.

4) Adjustment mechanisms are listed in the sequence as they are coming from the common rotating table. Fig.2 and 3 show the crystal adjustment mechanics for HLD-1 and APM-2 monochromator respectively.

5) Adjustment mechanisms are listed in the sequence as they are coming from the bottom.

Repeatability is defined as the largest difference between the primary position and the position to which mechanics returns after a specified loop of travel.

We give here the values of resolution, accuracy and errors, based on that measured during the mechanical tests in the factory.

II. Mechanics

3. Main Rotation Axis

■ Specifications

Model	HLD-1	HLD-2	HLD-3	APM-2
Bragg angle range	5° - 30°	5° - 30°	5° - 40°	5° - 60°
Drive	AC servomotor	AC servomotor	AC servomotor	AC servomotor
Theoretical resolution	0.1"/ step	0.1"/ step	0.1"/ step	0.1"/ step
Maximum velocity	1.4° / s	1.4° / s	1.4° / s	1° / s
Resolution	1"	1"	1"	1"
Absolute accuracy	10"	10"	10"	20"
Accuracy within 2° scan	5"	5"	5"	5"
Repeatability	1"	1"	1"	1"
Backlash / Lost motion	10"	10"	10"	10"
Table pitch	-----	-----	-----	7" / 1°
Axial wobble / Surface runout	-----	-----	-----	5 μm
Momentum load error	-----	-----	-----	0.1"/ kg-cm
Encoder	Heidenhain ERO-725-3	Heidenhain ERO-725-3	Heidenhain ERO-725-3	Heidenhain ROD-800



APM-2L "Left-side" monochromator : a general view.

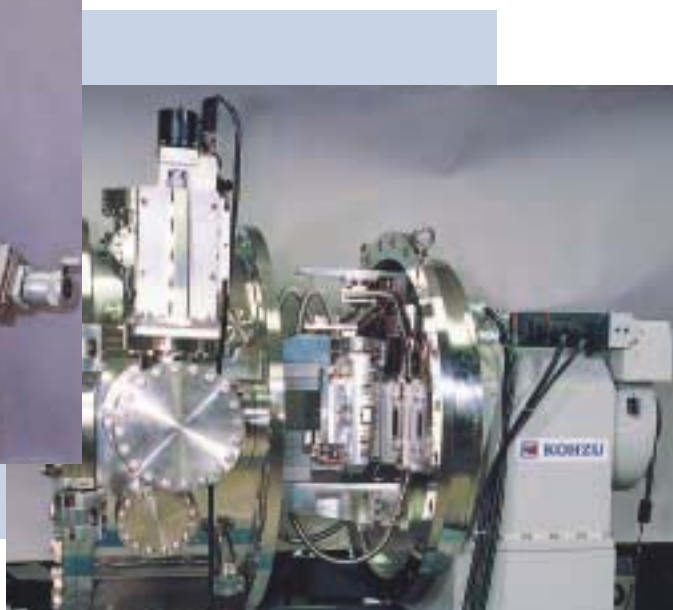

APM-2L monochromator: crystal adjustment mechanics.

4. First Crystal Part

■ Parameters of the crystals and the holders

Model	HLD-1	HLD-2	HLD-3	APM-2
Crystal sizes [mm]	100×100×25 ¹⁾	100×100×25 ¹⁾	100×100×25	70×60×80
Width x Length x Thickness	75×250×25 ²⁾	75×250×25 ²⁾		
Maximum load	10kg	10kg	10kg	10kg
Crystal orientation	1) flat 2) inclined	1) flat 2) inclined	flat	flat

■ Vertical translation Y1 - adjustment of the crystal surface with respect to the beam

Model	HLD-1	HLD-2	HLD-3
Motion range	±5mm	-7 ~ +3 mm	-23 ~ +2mm
Drive	5phase stepping motor	5phase stepping motor	5phase stepping motor
Theoretical resolution	0.2 μm / step	0.2 μm / step	0.2 μm / step
Accuracy	10 μm	10 μm	5 μm
Repeatability	-----	-----	1 μm
Angular errors - Crystal pitch	1"	1"	1"
- Crystal yaw	10"	10"	1"

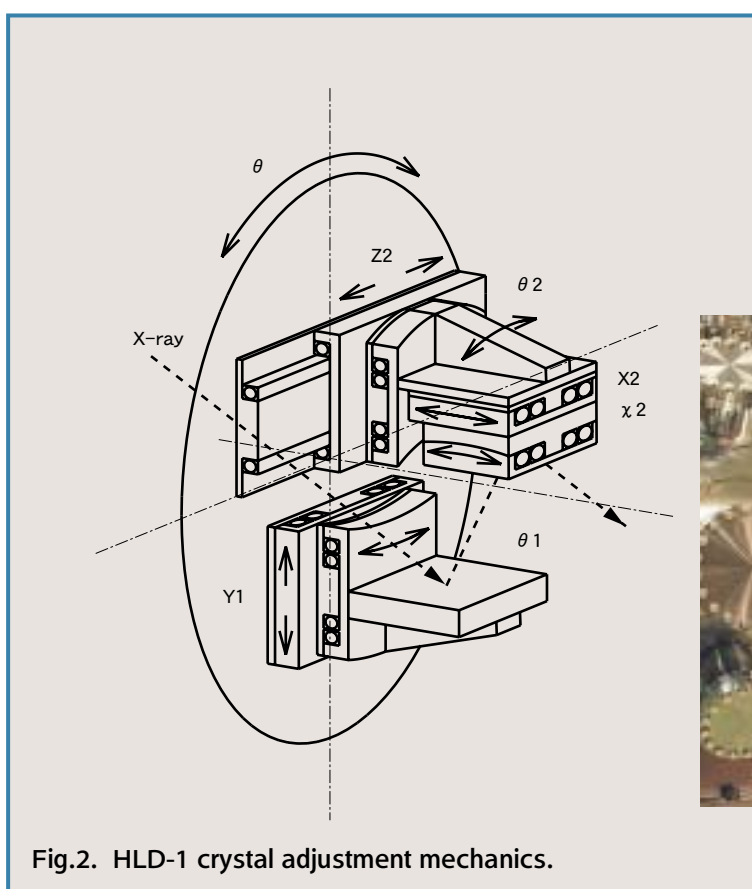

Crystal adjustment mechanics of HLD-1 monochromator.

■ Pitch θ_1 - adjustment of the Bragg angle

Model	HLD-1	HLD-2
Motion range - manual	±1°	±1°
- piezo	60"	60"
Drive	manual and piezoactuator	manual and piezoactuator
Accuracy - manual	60"	
- piezo	0.1"	0.1"
Axial wobble	10"	-----

II. Mechanics

5. Second Crystal Part

■ Parameters of the crystals and the holders

Model	HLD-1	HLD-2	HLD-3	APM-2
Crystal sizes [mm]	100×250×10 ¹⁾	100×250×10 ¹⁾	100×100×2	70×200×40
Width x Length x Thickness	75×250×10 ²⁾	75×250×10 ²⁾	(ribbed)	
Maximum load	3kg	3kg	3kg	10kg
Crystal orientation	1)flat 2)inclined	1)flat 2)inclined	flat sagittal focusing	flat

■ Longitudinal translation Z_2 - adjustment of the crystal surface with respect to the beam

Model	HLD-1	HLD-2	HLD-3	APM-2
Motion range	0 - 120mm ¹⁾	0 - 120mm ¹⁾	0 - 120mm ¹⁾	± 50 mm ²⁾
Drive	5 phase stepping motor	5 phase stepping motor	5 phase stepping motor	5 phase stepping motor
Theoretical resolution	2 μm / step	2 μm / step	2 μm / step	0.2 μm / step
Resolution	-----	-----	2 μm	1 μm
Absolute accuracy	-----	-----	5 μm	10 μm
Backlash / Lost motion	-----	-----	1 μm	2 μm
Straightness	-----	-----	-----	2 μm
Maximum velocity	-----	-----	5mm / s	1mm / s
Angular errors:				
Crystal pitch	1"	1"	1"	5"
Crystall yaw	20"	10"	10"	10"
Momentum load error	-----	-----	-----	0.1" / kg-cm

1) "0" corresponds to the crystal center position 40mm shifted longitudinally from the position above the rotation axis at $\theta = 0^\circ$.

2) The same as 1), however, the shift is 60mm.

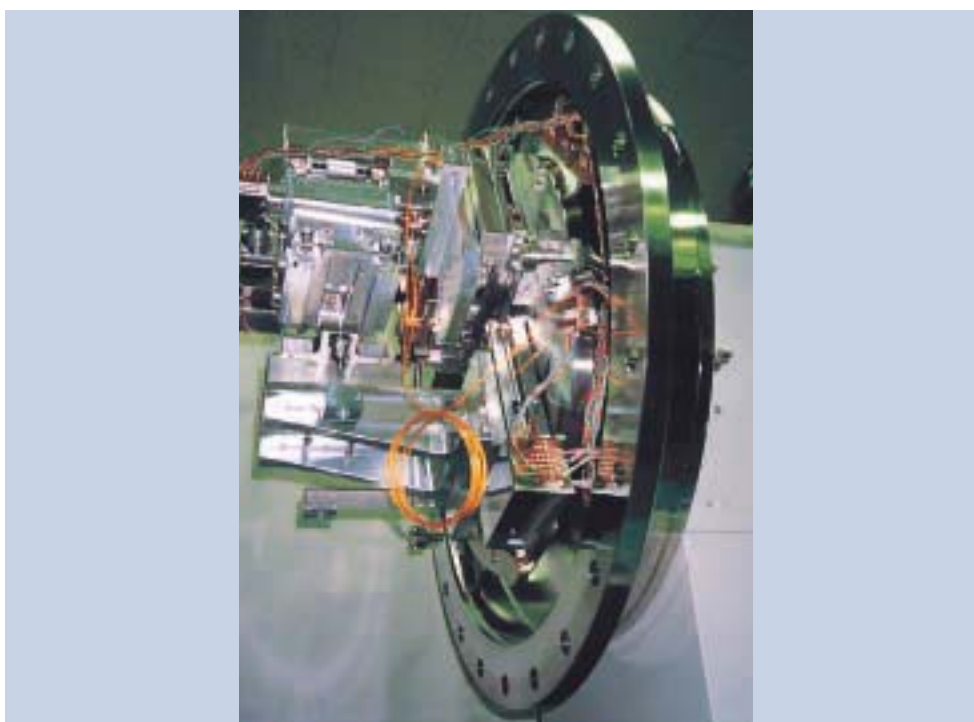

HLD-3 crystal adjustment mechanics.

■ Vertical translation Y_2 - adjustment of the offset

Model	APM-2
Motion range	$\pm 15\text{mm}$
Drive	5 phase stepping motor
Theoretical resolution	$0.2\ \mu\text{m} / \text{step}$
Resolution	$0.5\ \mu\text{m}$
Absolute accuracy	$5\ \mu\text{m}$
Backlash / Lost motion	$2\ \mu\text{m} / 1\ \mu\text{m}$
Straightness	$1\ \mu\text{m}$
Maximum velocity	$0.5\text{mm} / \text{s}$
Angular errors:	
Crystal pitch	$10''$
Crystal roll	$5''$
Momentum load error	$0.2'' / \text{kg-cm}$

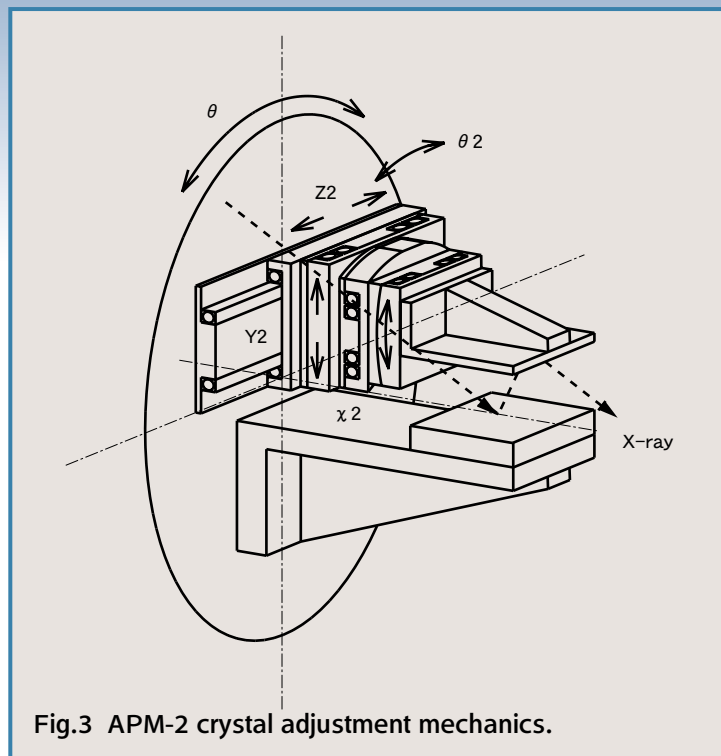

Fig.3 APM-2 crystal adjustment mechanics.

■ Pitch θ_2 - adjustment of the Bragg angle

Model	HLD-1	HLD-2	HLD-3	APM-2
Motion range - mechanics	$\pm 1^\circ$	$\pm 1^\circ$	$\pm 1^\circ$	$\pm 1^\circ$
- piezo	$60''$	$60''$	$\pm 60''$	$\pm 15''$
Drive	5 phase stepping motor and piezoactuator	5 phase stepping motor and piezoactuator	5 phase stepping motor and piezoactuator	5 phase stepping motor and piezoactuator
Theoretical resolution (mechanical)	$1'' / \text{step}$	$1'' / \text{step}$	$1'' / \text{step}$	$0.01'' / \text{step}$
Accuracy (mechanical)	$5''$	$5''$	$5''$	$2.5''$
Backlash / Lost motion (mechanical)	$20''$	-----	$0.5''$	$0.1''$
Repeatability	$5''$	$5''$	$5''$	$0.1''$
Axial wobble	-----	-----	-----	$3\ \mu\text{m}$
Surface runout				
Momentum load error	-----	-----	-----	$0.2'' / \text{kg-cm}$

II. Mechanics

■ Transverse translation X_2 -adjustment of the crystal surface with respect to the beam

Model	HLD-1	HLD-2	HLD-3
Motion range	$\pm 12.5\text{mm}$	12.5mm	12.5mm
Drive	5phase stepping motor	5phase stepping motor	5phase stepping motor
Theoretical resolution	$0.1 \mu\text{m} / \text{step}$	$0.1 \mu\text{m} / \text{step}$	$0.1 \mu\text{m} / \text{step}$
Accuracy	$10 \mu\text{m}$	$10 \mu\text{m}$	$1 \mu\text{m}$
Repeatability	-----	-----	$1 \mu\text{m}$
Angular errors	yaw 10"	-----	5"yaw , pitch

■ Roll χ_2 -adjustment of the exit beam direction

Model	HLD-1	HLD-2	HLD-3
Motion range	$\pm 5^\circ$	$\pm 5^\circ$	$\pm 8^\circ$
Work distance ¹⁾	95mm	95mm	95mm
Drive	5 phase stepping motor	5 phase stepping motor	5 phase stepping motor
Maximum velocity	-----	-----	-----
Theoretical resolution	-----	-----	-----
Resolution	1"	1"	1"
Backlash / Lost motion	-----	-----	-----
Axial wobble	-----	-----	-----
Surface runout	-----	-----	-----
Momentum load error	-----	-----	-----

1) Distance from the table surface to rotation center.

■ Yaw ϕ_2 - adjustment of the exit beam direction

Model	HLD-3
Motion range	$\pm 2^\circ$
Drive	5 phase stepping motor
Theoretical resolution	$0.002^\circ / \text{step}$
Resolution	HLD-3
Accuracy	15"
Axial wobble	$5 \mu\text{m}$
Surface runout	

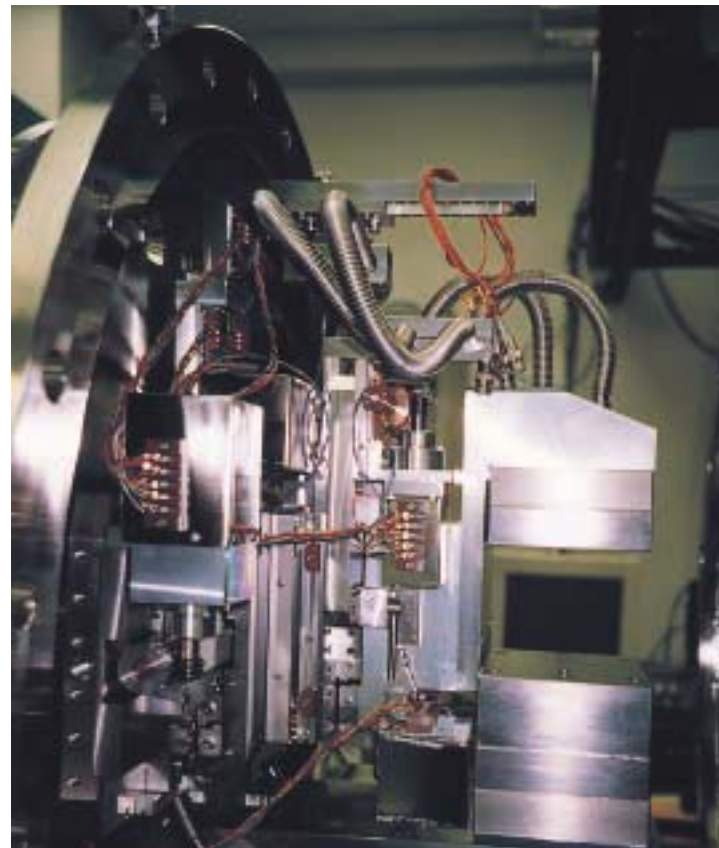

APM-2 crystal adjustment mechanics.

6. Sagittal focusing

A sagittal focusing mechanism is installed on HLD-3 monochromators only. The bender model SMB-1 has been originally developed for SPring-8 Japanese synchrotron radiation facility. Characteristic feature of the bender is that the crystal surface position remain almost unchanged in the center, where the beam hits the crystal. Design outline of the bender is shown on fig.4. The crystal is clamped by 4 freely rotating cylinders fixed in two arms. Pushing of the arms (as shown by arrows) from the bottom leads to their tilting and bending of the crystal.

Drive	5 phase stepping motor
Linear motion range	2mm
Crystal sizes: width - length - thickness	100mm×100mm×2mm ¹⁾
Minimum bending radius ²⁾	0.47m
Maximum surface runout at the center ³⁾	0.3mm

- 1) The best result has been achieved for the width x length ratio 3:2 and 2mm thick ribbed crystal (Y.Furukawa, Y.Yoneda - SPring-8, private communication, January 1998).
- 2) This is idealized value for maximum linear shift 2mm. Bending down to radius 1m has been achieved during the tests at SPring-8 (Y.Furukawa, Y.Yoneda - *ibid.*).
- 3) This is idealized value for maximum linear shift 2mm. At bending radius 1m there have been observed surface shift 0.25mm for 2mm ribbed crystal (Y.Furukawa, Y.Yoneda - *ibid.*).

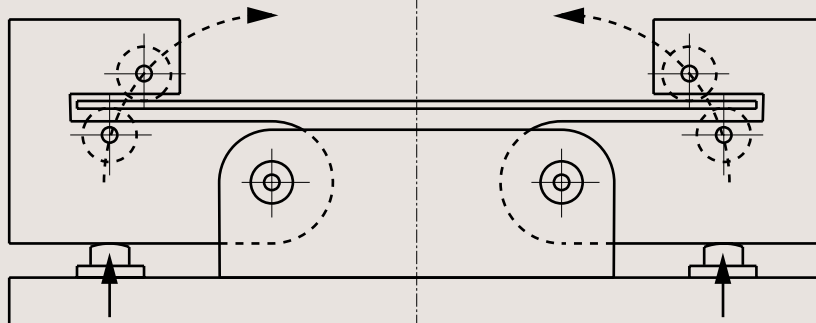
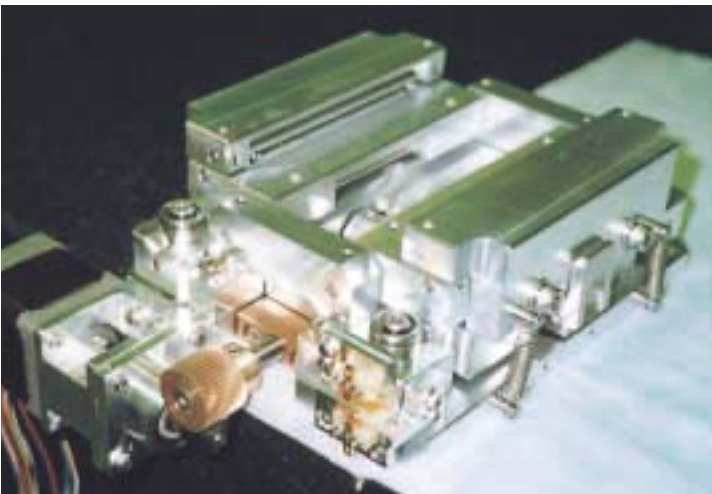

Fig.4. SMB-1 bender.

II. Mechanics

7. Supporting Table

The supporting table holds the whole monochromator with the vacuum chamber. It has possibilities for horizontal and vertical translation, as well as $\pm 2^\circ$ tilting by adjustment bolts on the bottom. There are optional removable wheels at the bottom of the table for easy transportation of the monochromator.

■ Vertical translation Y_T - adjustment of the monochromator height with respect to the beam

Model	HLD-1	HLD-2	HLD-3	APM-2
Motion range	$\pm 25\text{mm}$	$\pm 25\text{mm}$	$\pm 25\text{mm}$	$\pm 50\text{mm}$
Drive	5phase stepping motor	5phase stepping motor	5phase stepping motor	5phase stepping motor
Theoretical resolution	$1\ \mu\text{m} / \text{step}$	$1\ \mu\text{m} / \text{step}$	$1\ \mu\text{m} / \text{step}$	$0.1\ \mu\text{m} / \text{step}$
Accuracy	0.1mm	0.1mm	0.1mm	-----
Angular errors	-----	-----	-----	20" pitch, yaw
Straightness	-----	-----	0.5mm	0.5mm

■ Transverse translation X_T -adjustment of transverse horizontal position of whole monochromator with respect to the beam

Model	HLD-1	HLD-2	HLD-3	APM-2
Motion range	$\pm 25\text{mm}$	$\pm 25\text{mm}$	$\pm 25\text{mm}$	$\pm 50\text{mm}$
Drive	5phase stepping motor	5phase stepping motor	5phase stepping motor	manual
Theoretical resolution	$1\ \mu\text{m} / \text{step}$	$1\ \mu\text{m} / \text{step}$	$1\ \mu\text{m} / \text{step}$	$10\ \mu\text{m}$ readout
Accuracy	0.1mm	0.1mm	0.1mm	-----
Angular errors	-----	-----	-----	20"pitch, yaw
Straightness	-----	-----	-----	0.5mm

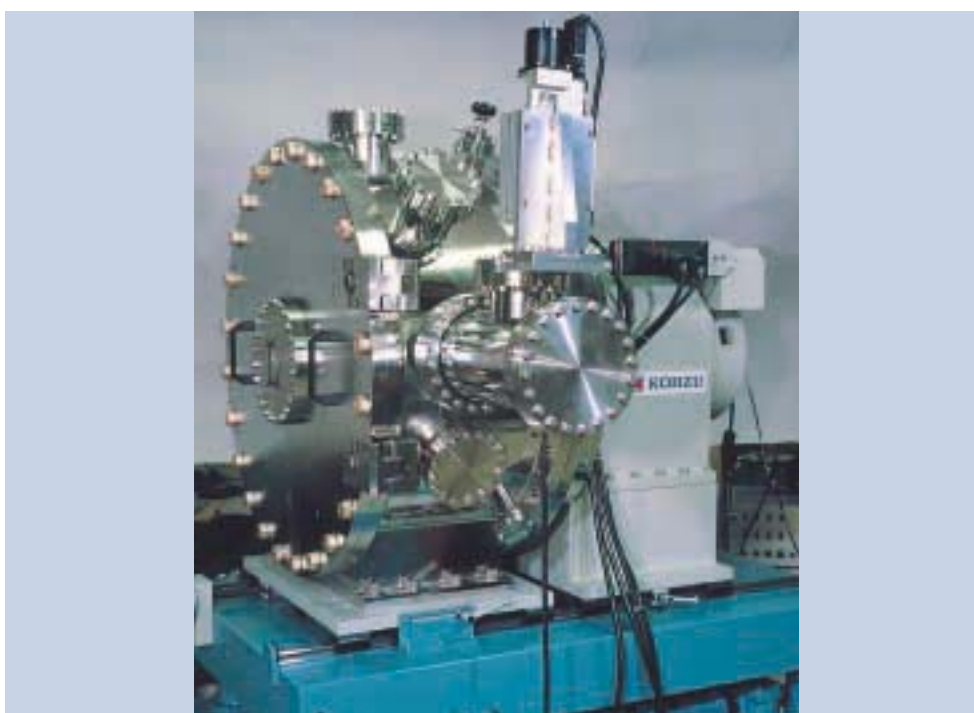

Fully equipped APM-2L monochromator.

III. Vacuum Chamber

The vacuum chamber of all HLD and APM series monochromators is a stainless steel cylinder with 720mm inner diameter. There are two side flanges of 850mm in diameter. One is fixed to the column with the main rotation axis mechanism. The other one is free and can be opened in order to have access to the monochromator mechanics. The interior part of the chamber is electropolished. All flanges are sealed by Viton O-rings. Sizes and positions of flanges on the standard vacuum chamber body are shown on fig.5. However, the flanges can be changed according to the needs of the customer. The vacuum chamber is pumped by an optical Perkin-Elmer 400l/s ion pump as a standard.

There is an optical fluorescent screen beam monitor inside cylindrical tube connected to the beam exit flange. The screen can be observed through the side viewport. Motorized translation mechanism of the screen is on the air side and motion is transmitted to vacuum through a bellows.

All materials and lubricants used inside the vacuum chamber are high vacuum compatible.

Materials inside vacuum chamber

Metals	Plastics	Lubricants
Stainless steel, Aluminum alloy, Phosphor bronze	Kapton, Vespel, Aramide ¹⁾ , Irrax ²⁾	Moresco Hirad ³⁾ Fomblin

1) Oiles Industry;

2) Sumitomo Electric;

3) Matsumura Oil Research Corp.

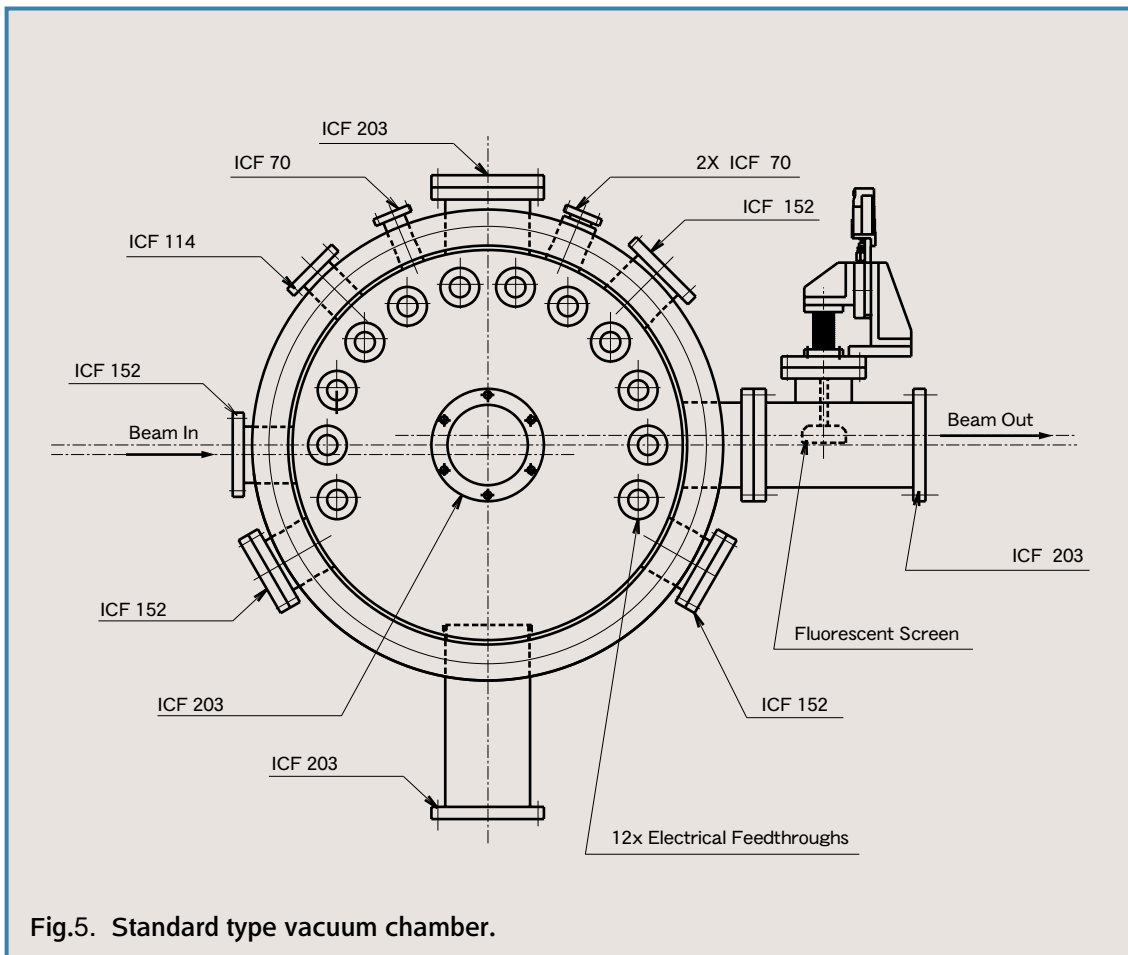

Fig.5. Standard type vacuum chamber.

IV. Electrical Connections

All motors except the main rotation axis mechanism are 5-phase stepping motors. The motors used inside the vacuum chamber are UHV compatible. The main axis is provided with an AC servomotor and angular encoder. All motorized motions are provided with driver electronics and limit switches which are high vacuum compatible where necessary. Cabling inside the vacuum chamber is vacuum compatible and radiation proof.

■ General specifications

Line voltage	single phase 100 ± 10%
Line frequency	50 / 60 Hz
Power	2 kW
Maximum distance between drivers and the monochromator	20 m
Cable insulation inside the vacuum chamber	Kapton Irrax ¹⁾

1) Sumitomo Electric

■ 5 phase stepping motor drivers

Driver type	constant current, bipolar pentagon
Minimum input pulse width	5 μs
Minimum input pulse-to-pulse interval	5 μs
Maximum input pulse rise/fall time	1 μs
Maximum input pulse rate	70kHz
Input pulse level	H:4~12 V L:0.5~12 V
Input resistance (photocoupler)	390 Ω

■ AC servomotor driver (the main axis only)

Model	HLD-3	Other models
Driver type	Sine wave PWM - FET inverter	Sine wave PWM - FET inverter
Minimum input pulse width	2 μs	5 μs
Minimum pulse period	5 μs	20 μs
Maximum input pulse rise/fall time	2 μs	2 μs
Maximum input pulse rate	200kHz	50kHz
Input pulse level	H:4~5 V L:0~0.5 V	H:4~5 V L:0~0.5 V
Input current(photocoupler)	10~25 mA	10~30 mA
Output type	Open collector, photocoupler	Open collector, photocoupler
Maximum signal output voltage / current	30 V / 20 mA	30 V / 20 mA
Maximum encoder output voltage / current	15 V / 2 mA	15 V / 2 mA

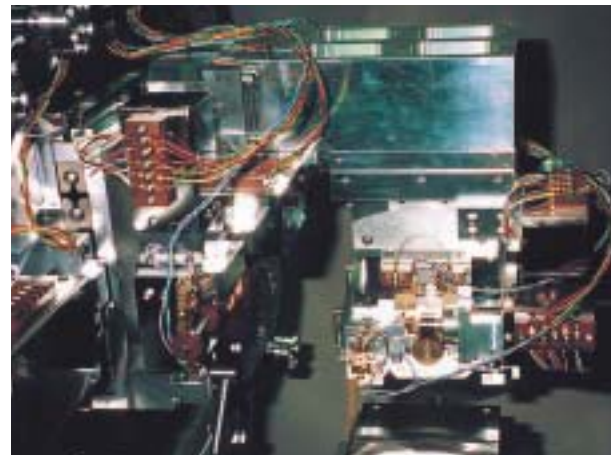

HLD-3 monochromator:
wiring inside the vacuum chamber.

V. Cooling system

There are tubes going from the air side of the main axis shaft to inner part of the vacuum chamber for cooling of both crystals and optionally other parts. Cooling tubes can be adapted according to the customer needs.

Model	HLD-1	HLD-2	HLD-3	APM-2
Coolant	Liquid Nitrogen ¹⁾	Liquid Gallium, water ²⁾	Liquid Nitrogen	water ²⁾
Number of tubes provided	2 pairs	2 pairs	2pairs	3pairs
Tubes provided to	crystal holders	crystal holders	rotation table	crystal holders, radiation shield
Tube inner diameter	10.4 mm	10.4 mm	10.7 mm	8 mm
Working pressure	3 kg / cm ²	3 kg / cm ²	3 kg / cm ²	3 kg / cm ²
Tube design and material	Stainless steel, teflon with stainless steel braid	Stainless steel, teflon with stainless steel braid	Stainless steel, teflon with stainless steel braid	Inner : Teflon, Outer : stainless steel bellow, space between pumped

1) Working circulation rate about 6~10 ℓ /min. Liquid Gallium an water cooling is possible too.

2) Designed for



APM-2 monochromator : cooling tubes inside vacuum chamber.

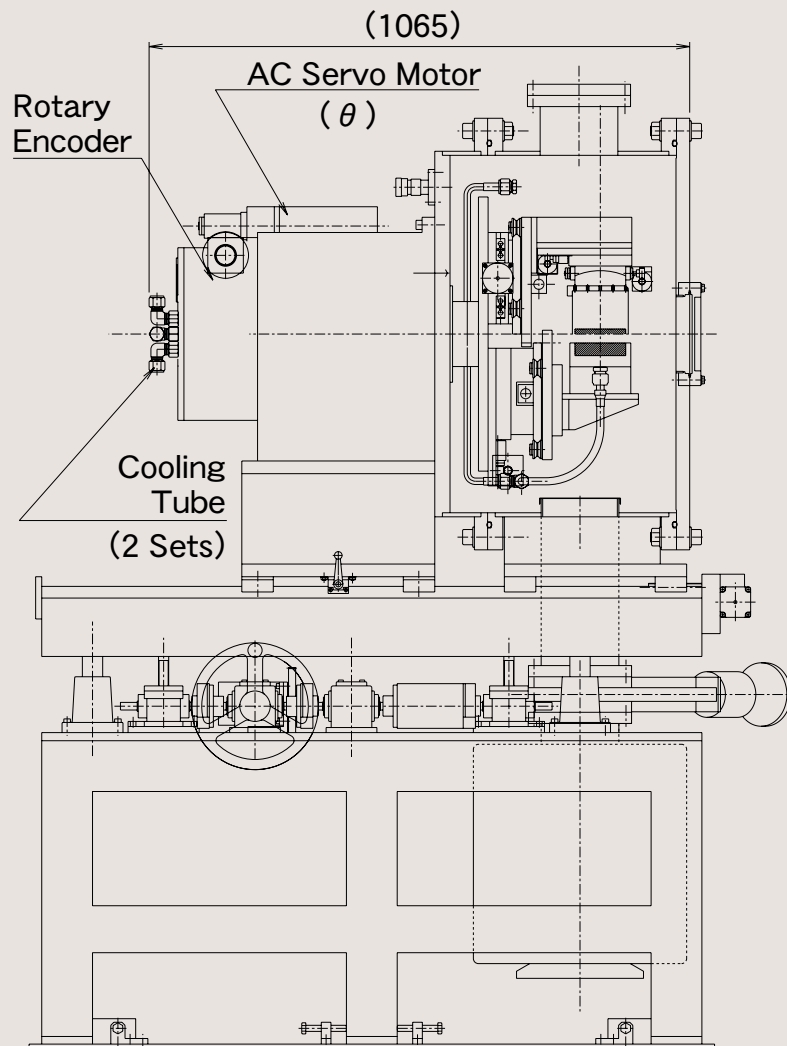
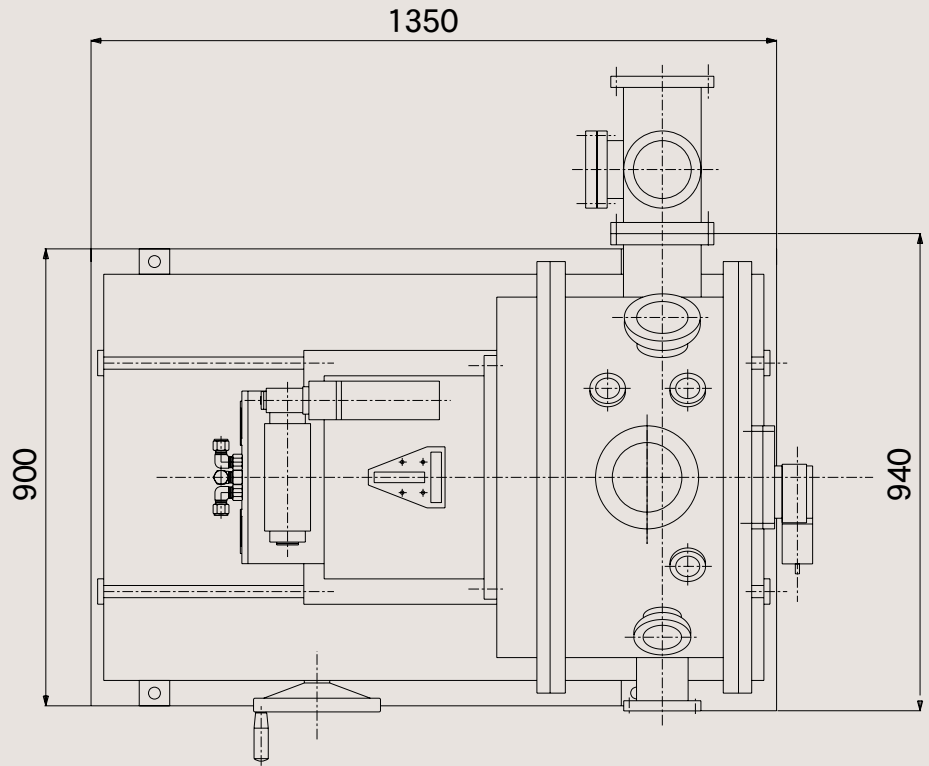

VI. General View Drawings

Fig.6. HLD-1 type monochromator.
Exterior of all other types is practically the same.

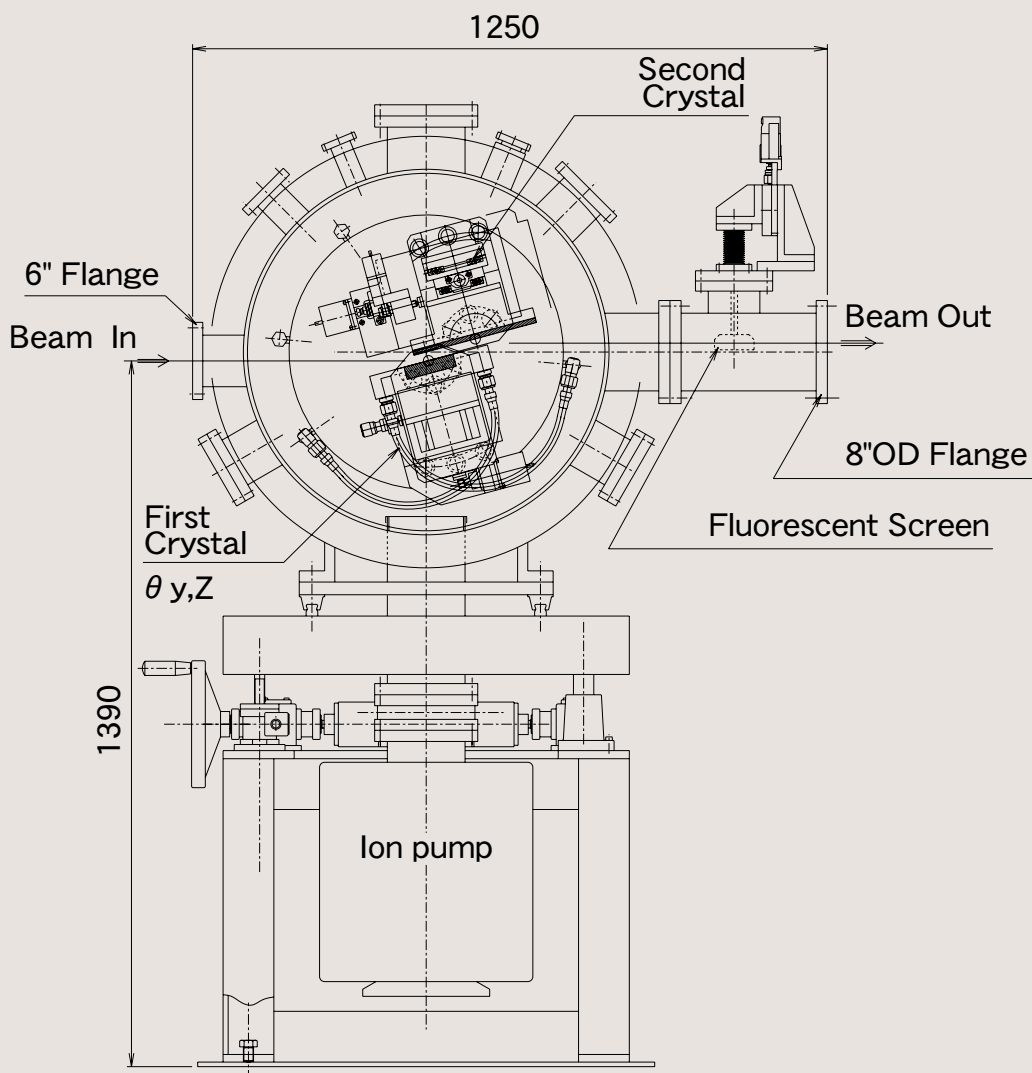



KOHZU Precision Co, Ltd.

2-6-15 Kurigi, Asao-ku, Kawasaki City, Kanagawa, 215-8521, JAPAN

Phone: +81-44-981-2131 Fax: +81-44-981-2181

e-mail: sale@kohzu.co.jp Web: www.kohzu.co.jp